

THIS DRAWING IS UNPUBLISHED. RELEASED FOR PUBLICATION  
 © COPYRIGHT BY TYCO ELECTRONICS CORPORATION. ALL RIGHTS RESERVED.

LOC	DIST	REVISIONS			DAP		
G	14	P	LTR	DESCRIPTION	DATE	DWN	APVD
		E1		REV PER ECR 06-027811	30NOV06	JR	TM

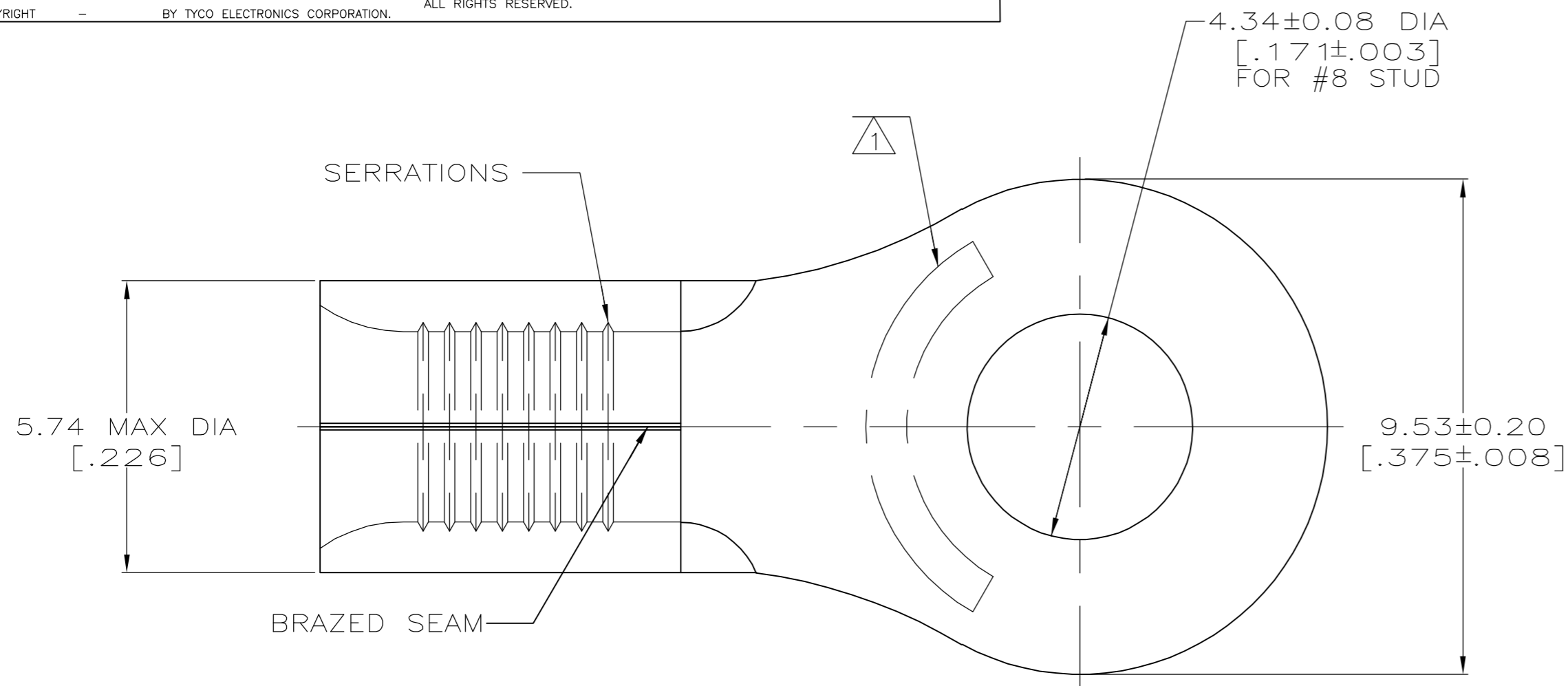

<b>AMP</b> WIRE RANGE	Listed FILE E13288	LR7189 Certified
12-10 AWG SOLID OR STRANDED	12-10 AWG STRANDED	12-10 AWG SOLID OR STRANDED

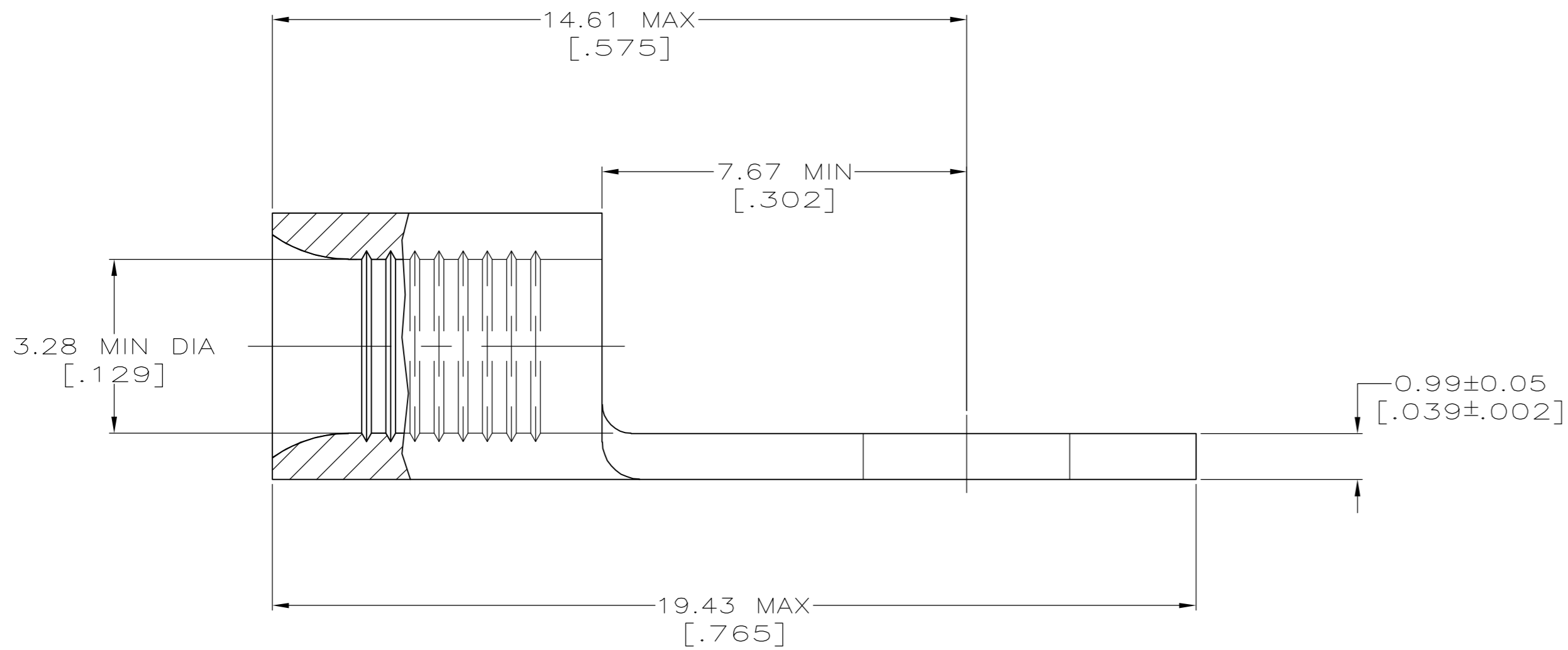

- ① STAMP AMP 12-10\* APPROX AS SHOWN
- ② COPPER PER ASTM B-152, ANNEALED
- ③ TIN PLATE 0.00254 [.000100] MIN THK PER ASTM B545
- ④ TIN/LEAD (93-7) PLATE PER ASTM B545 ( 3% MIN LEAD CONTENT ).

25	③	LOOSE PIECE, BAG	8-32994-5
50	③	LOOSE PIECE, BOX	8-32994-2
2500	③	ON TAPE	2-32994-1
500	④	LOOSE PIECE	32994-1
500	③	LOOSE PIECE	32994
QUANTITY	FINISH	PACKAGING TYPE	PART NO.

<b>AMP INCORPORATED CUSTOMER SERVICE SYSTEMS</b>		MAX RECOMMENDED OPERATING TEMPERATURE: 170°C
FOR ADDITIONAL PRODUCT INFORMATION OR COPIES OF DRAWINGS AND TECHNICAL DOCUMENTS	PRODUCT INFORMATION CENTER 1-800-522-6752	VOLTAGE RATING: N/A
FOR APPLICATION TOOLING INFORMATION	TOOLING ASSISTANCE CENTER 1-800-722-1111	CIRCULAR MIL AREA: 2.62-6.64mm <sup>2</sup> [5,180-13,100] SOLID OR STRANDED
FOR ORDER ENTRY	1-800-526-5142	THIS DRAWING IS A CONTROLLED DOCUMENT FOR AMP INCORPORATED. IT IS SUBJECT TO CHANGE AND THE CONTROLLING ENGINEERING ORGANIZATION SHOULD BE CONTACTED FOR THE LATEST REVISION.

THIS DRAWING IS A CONTROLLED DOCUMENT.		DWN TA BRINKMAN 3-17-93	Tyco Electronics Corporation Harrisburg, PA 17105-3608	
DIMENSIONS: MM [ INCHES ]		CHK DA PATTERSON 3-17-93	NAME JL MECKLEY 3-17-93	
TOLERANCES UNLESS OTHERWISE SPECIFIED:		APVD JL MECKLEY 3-17-93	PRODUCT SPEC	
0 PLC ± -		APPLICATION SPEC		
1 PLC ± -		-		
2 PLC ± -		-		
3 PLC ± -		-		
4 PLC ± -		-		
ANGLES ± -		-		
MATERIAL	②	FINISH	WEIGHT	SIZE
	SEE NOTES		-	A2
CUSTOMER DRAWING		CAGE CODE	DRAWING NO	RESTRICTED TO
		00779	C=32994	-
SCALE		SHEET	REV	
10:1		1 of 1	E1	